

matical statement of the problem (based on the Pölya-de Bruijn model²³) was discussed elsewhere.^{7a,9,24} To date, the algorithms for generation of SEQ's are verified and the appropriate computer programs are written (ELSE,⁸ SYMBEQ⁹). Thus, we can now create and graphically output the complete sets of SEQ's for every given topology.^{25,26}

Conclusion

The formal-logical approach is an a priori formulation of necessary structural requirements incorporated into structures of reactants to perform a bond redistribution of a particular type. Such a treatment can be accomplished in a rigorous way to obtain, and what is more, to constructively enumerate complete sets of SEQ's for every topology of bond redistribution. The introduction of element symbols instead of reaction center symbols enables them to be used as the instrument in the search for new reactions. This approach

(23) Faradzhev, I. A. In *Algorithmic Studies in Combinatorics*; Nauka: Moscow, 1978; p 3 (in Russian).

(24) (a) Generation of SEQ's needs in some cases an algorithmization of a special subgroup of generalized wreath product.^{24b} (b) Zefirov, N. S.; Kaluzhnin, L. A.; Tratch, S. S. In *Algebraic Theories of Combinatorial Objects*; Faradzhev, I. A., Klin, M. H., Eds.; VINITI: Moscow, 1985; p 175 (in Russian).

(25) This approach was also used for a description of mechanisms of organic reactions.^{9c}

(26) This approach was successfully used as logical basis of the program for nonempirical computer-assisted synthesis (FLAMINGOES).⁷

also represents an extensive and rigorous classification system of organic reactions, which may be used for information storage.

Of course, the depth of one's penetration into any problem will never exceed the limit of the theory used. This approach is based on the structural theory; moreover, it is the next step in the development of structural theory up to the computerized form. Thus, it may give as much as that theory may provide. In all applications of structural theory to problems of reactivity, one may pose a question (i.e., write a proposed reaction),^{3,4} but only experiment can judge the reality of its performance.

To predict the course of a chemical reaction, one needs to supplement the structural basis with a knowledge of thermodynamics, kinetics, mechanisms, MO considerations, stereochemical demands, etc. Only an "alloy" of different branches of present theories will be the framework of the future theory of organic reactions.

I thank all authors whose results have been used for illustration without proper citation due to space limitations. I am in debt to Professors J. Gasteiger, J. Brandt, K. Burger, P. von R. Schleyer, W. A. Smit, and other professional colleagues for their helpful discussions. I thank my co-workers I. I. Baskin, G. A. Gamziani, and E. V. Gordeeva. I am especially thankful to Dr. S. S. Tratch with whom I have had the pleasure to share the joys and frustrations of research in this field.

Acyclic Stereocontrol via Allylic Organometallic Compounds

YOSHINORI YAMAMOTO

Department of Chemistry, Faculty of Science, Tohoku University, Sendai 980, Japan

Received November 26, 1986 (Revised Manuscript Received February 27, 1987)

Acyclic stereocontrol is a pressing concern in modern organic chemistry,¹ and a number of methods have been developed for the stereoregulated synthesis of conformationally nonrigid complex molecules, such as macrolide and polyether antibiotics.¹ Special attention has been paid to aldol reactions, which constitute one of the fundamental bond constructions in biosynthesis. The reaction of allylic organometallic reagents (1) with aldehydes is synthetically analogous to the aldol addition of metal enolates (2),² since the resulting homoallyl alcohol (3) can be easily converted to the aldol (4).³ Further, the allylmetal additions have significant advantages over aldol condensations, since the alkenes may be readily transformed into aldehydes (5),² may undergo a facile one-carbon homologation to δ -lactones (6) via hydroformylation,⁴ or may be selectively epoxidized to introduce a third chiral center (7).⁵ Nowadays, the allylic organometallic method has become

Yoshinori Yamamoto was born in Kobe in 1942 and received his B.S. and Ph.D. degrees from Osaka University. After spending 2 years as a postdoctoral fellow at Purdue University with Herbert C. Brown, he served as Lecturer at Osaka University (1972-1976) and Associate Professor at Kyoto University (1977-1985). He moved to Tohoku University as Professor of Chemistry in 1986. His research interests include exploration of new synthetic methodologies, organometallic chemistry, and asymmetric science.

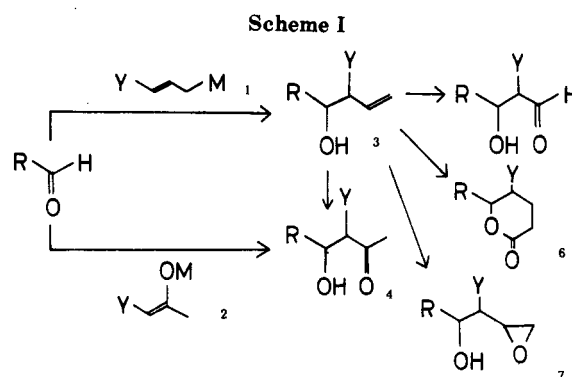

one of the most useful procedures for controlling the stereochemistry in acyclic systems.

(1) Reviews: (a) Heathcock, C. H. In *Asymmetric Synthesis*; Morrison, J. D., Ed.; Academic: New York, 1984; Vol. 3, p 111. (b) Evans, D. A.; Nelson, J. V.; Taber, T. R. *Top. Stereochem.* 1982, 13, 1. (c) Mukaiyama, T. *Org. React. (N.Y.)* 1982, 28, 203. (d) Masamune, S.; Choy, W.; Peterson, J. S.; Sita, L. R. *Angew. Chem., Int. Ed. Engl.* 1985, 24, 1. (e) MaGarvey, G. J.; Kimura, M.; Oh, T.; Williams, J. M. J. *Carbohydr. Chem.* 1984, 3, 125. (f) Reetz, M. T. *Angew. Chem., Int. Ed. Engl.* 1984, 23, 556. (g) Seebach, D.; Prelog, V. *Angew. Chem., Int. Ed. Engl.* 1982, 21, 654. (h) Bartlett, P. A. *Tetrahedron* 1980, 36, 2.

(2) (a) Yamamoto, Y.; Maruyama, K. *Heterocycles* 1982, 18, 357. (b) Hoffmann, R. W. *Angew. Chem., Int. Ed. Engl.* 1982, 21, 555.

Scheme II

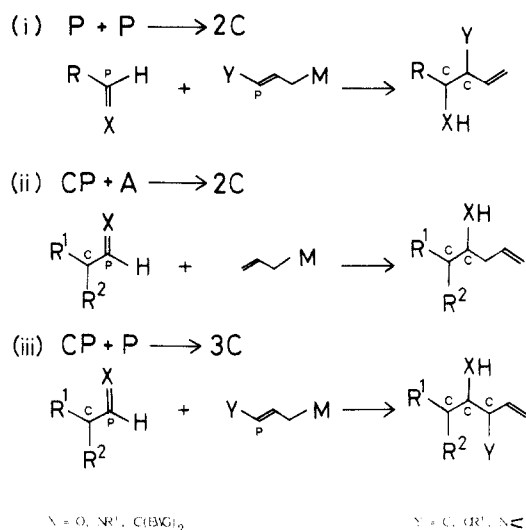

Before 1978, a major synthetic interest in allylic organometallic chemistry had been the regioselective carbon-carbon bond formation between allylic metals and electrophiles; the S_E2 or S_E2' problem.⁶ In 1978, Heathcock⁷ reported the anti-selective addition of (*E*)-crotylchromium(II) reagents⁸ to aldehydes. Starting from the effective addition of allylboronates,^{9a} in 1979 Hoffmann found the syn-selective condensation of (*Z*)-crotylboronates to aldehydes.^{9b} About 10 years ago, we became interested in allylic organometallic chemistry, and both (*E*)- and (*Z*)-2-alkenylboronates came to our hand.¹⁰ In 1978, we reported regiocontrolled head-to-tail coupling of allylic boron "ate" complexes with allylic halides,¹¹ and at that time we started to study acyclic stereocontrol via allylic organometallic compounds under the stimulus of the papers of Heathcock⁷ and Hoffmann.^{9b}

Asymmetric induction with allylic organometallic reagents (also with enolates) is divided into three elemental processes: (i) $P + P \rightarrow 2C$, (ii) $CP + A \rightarrow 2C$, and (iii) $CP + P \rightarrow 3C$, where P means a prochiral center, C means a chiral center, and A means an achiral center. The so-called erythro/threo problem, i.e., simple diastereoselectivity, belongs to (i). The Cram/anti-Cram problem, i.e., diastereofacial stereoselectivity, is related to (ii). Either by (i) or by (ii), we can create two asymmetric centers (2C control). Higher ordered control of three consecutive carbon units (3C control)

(3) Yatagai, H.; Yamamoto, Y.; Maruyama, K. *J. Am. Chem. Soc.* **1980**, *102*, 4548.

(4) Wuts, P. G. M.; Obrzut, M. L.; Thompson, P. A. *Tetrahedron Lett.* **1984**, *25*, 4051.

(5) Yamamoto, Y.; Yatagai, H.; Maruyama, K. *J. Am. Chem. Soc.* **1981**, *103*, 3229.

(6) (a) For reviews, see: Courtois, G.; Miginiac, L. *J. Organomet. Chem.* **1974**, *69*, 1. Schlosser, M. *Angew. Chem., Int. Ed. Engl.* **1974**, *13*, 701. Benkeser, R. A. *Synthesis* **1971**, 347. Mikhailov, B. M. *Organomet. Chem. Rev., Sect. A* **1972**, *8*, 1. Chan, T. H.; Fleming, I. *Synthesis* **1979**, 761. (b) The stereochemical aspect on the thermal reaction of crotyltin (*E* and *Z* mixture) with activated aldehydes was briefly studied by Pereyre in 1972: Servens, C.; Pereyre, M. *J. Organomet. Chem.* **1972**, *35*, C20.

(7) Buse, C. T.; Heathcock, C. H. *Tetrahedron Lett.* **1978**, 1685.

(8) Okude, Y.; Hirano, S.; Hiyama, T.; Nozaki, H. *J. Am. Chem. Soc.* **1977**, *99*, 3179.

(9) (a) Herold, T.; Hoffmann, R. W. *Angew. Chem., Int. Ed. Engl.* **1978**, *17*, 768. (b) Hoffmann, R. W.; Zeiss, H. *J. Angew. Chem., Int. Ed. Engl.* **1979**, *18*, 306.

(10) Brown, H. C.; DeLue, N. R.; Yamamoto, Y.; Maruyama, K.; Kasahara, T.; Murahashi, S.-I.; Sonoda, A. *J. Org. Chem.* **1977**, *42*, 4088.

(11) Yamamoto, Y.; Maruyama, K. *J. Am. Chem. Soc.* **1978**, *100*, 6282.

Table I.
Diastereoselectivity in the Reaction of 1

entry	1	aldehyde	condition	3 syn:anti	ref
1		Cl_3CCHO	20 °C	1:9	6b
	8:9 = 9:1				
2	9	Cl_3CCHO	25 °C	>99:-	3
3	9	PhCHO	BF_3	49:1	3, 12
4	8	PhCHO	BF_3	49:1	12
5		PhCHO	BF_3	1:>99	19
6	8	RCHO	$TiCl_4^a$	1:19	20
7		EtCHO	$TiCl_4$	19:1	21, 12
8		<i>n</i> -C ₆ H ₁₃ CHO	BF_3	10:1	23, 22
9		PhCHO	BF_3	2-49:1	24
10	18a-18d	PhCHO	BF_3	>9:1	25
11	18e	<i>i</i> -PrCHO	140 °C	-:>99	27
12		PhCHO	25 °C	1:2	26
13	8:9 = 7:3	PhCHO	10 kbar	1:2	28

^a A reversed addition procedure, (1) $TiCl_4$, (2) 8, (3) RCHO, was employed. ^b M = Cu, Cd, Hg, Tl, Zr, and V derivatives. ^c *E/Z* = 2/1.

is shown in (iii). First, we studied systematically (i) and (ii) with three typical electrophiles: aldehydes, aldimines, and α,β -unsaturated carbonyl derivatives. As nucleophiles, we used allyl, crotyl, and heterosubstituted allylic organometallic compounds. Next, we investigated (iii) and tried to predict the stereoselectivity on the basis of the information of (i) and (ii).

Reactions of Aldehydes

(i) Taking a hint from Pereyre's observation^{6b} on the crotyltin condensation reaction (Table I, entry 1), we developed a new method for the stereoselective synthesis of pure (*E*)- and (*Z*)-2-alkenyltins to disclose the stereoselectivity of the thermal reaction with ordinary aldehydes.³ The thermal reaction of 9 with the activated aldehyde afforded the syn isomer exclusively³ (entry 2), and 8 gave the anti isomer predominantly. Although the thermal reaction of 9 with benzaldehyde was quite sluggish, the BF_3 mediated condensation proceeded even at -78 °C to give the syn alcohol (entry 3).³ To our surprise, however, the BF_3 mediated reaction of 8 with benzaldehyde produced again the syn isomer (entry 4).¹²

This stereochemical outcome was quite unexpected, since it had been generally believed that the reaction of allylic organometals with aldehydes must proceed through a chairlike transition state^{2,13} (10 or 11) in which the metal cation can interact with the partially negative oxygen and, hence, that (*E*)-crotylmetals should selectively produce the anti alcohol (13) via 10. With other aldehydes, such as propanal and 2-methyl-1-propanal, the syn homoallyl alcohols were again obtained irrespective of the geometry of crotyltins. We applied the high syn-selective condensation to a short asymmetric synthesis of verrucarinolactone. The target molecule was prepared in 91% ee via the reaction of 8-phenylmenthyl glyoxylate with crotyltin in the presence of BF_3 .¹⁴

(12) Yamamoto, Y.; Yatagai, H.; Naruta, Y.; Maruyama, K. *J. Am. Chem. Soc.* **1980**, *102*, 7107.

(13) Zimmerman, H. E.; Traxler, M. D. *J. Am. Chem. Soc.* **1957**, *79*, 1920 and ref 1.

Scheme III

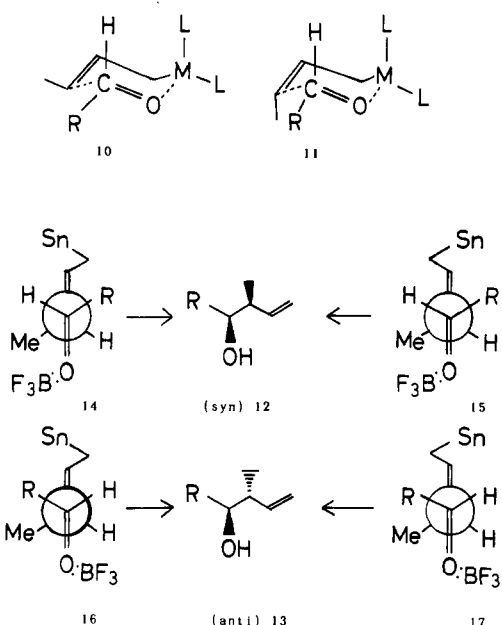

We proposed an acyclic transition state for the stereochemical convergence^{12,15,16} in which Lewis acids coordinate to the oxygen atom preventing the coordination of the Sn atom. Among several possible transition-state geometries, two conformations (14 and 15) leading to the syn alcohol (12) must be favored for steric reasons in comparison with those (16 and 17) leading to the anti isomer (13). Therefore, BF₃ coordination dramatically changes the reaction mechanism and the stereochemical outcome. Quite recently, the anti complexation of BF₃ to benzaldehyde has been established by X-ray crystallography.¹⁷ Consequently, the assumption of anti coordination shown in 14–17 is thus no longer a matter of pure speculation.

Although we proposed the antiperiplanar transition state (14–17), synclinal geometry was also suggested by Denmark in certain intramolecular allylmethyl condensation reactions.¹⁸ It seems to us that intramolecular steric congestion forces the reactions to take synclinal geometry. A problem on the antiperiplanar vs. synclinal transition state must await further investigation. The reversed stereoselectivity of entries 5 and 6 may be explained by a cyclic transition state like 10.

The stereoconvergent syn selectivity in the presence of Lewis acids was also observed for a wide range of

Scheme IV

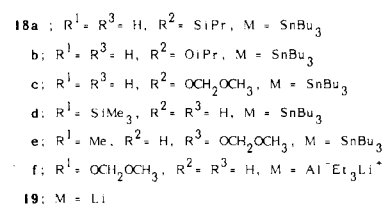
Table II.
Selectivity in the Reaction of 20

entry	reagent	21:22	total yield, %
1		1.2:1	98
2		4:1	96
3		5:1	93
4	BuLi·15-C-5	>30:1	91
5	BuLi	5:1	91
6		>30:1	87
7	Bu ₂ CuLi-18-C-6	1:4	95
8	Bu ⁻ N ⁺ Bu ₄	8:1	93
9	Bu ₂ Cu ⁻ NBu ₄	1:2	72

crotylmethyls with relatively low Lewis acidity²⁴ (entries 7–9). The reversal of diastereoselectivity is consistent with the acyclic transition states 14 and 15.

The functional group substituted allylic tins (18a–18d) also exhibited high syn selectivity in the presence of BF₃²⁵ (entry 10). These tin reagents were easily obtained by trapping the corresponding heteroatom substituted allylic carbanions (19) with Bu₃SnCl. It is interesting that the cis derivatives (18a–18c) were obtained from the sulfur and oxygen substituted carbanions, whereas the trans tin (18d) was produced from the trimethylsilylallyl carbanion. Since allylic double bonds hold their configuration, the double-bond geometry is presumably determined in the deprotonation reaction, rather than in coordination with tin. Without BF₃, 18e gave the anti adduct (entry 11).²⁷

It is now clear that many allylic organometals, including allylic tin reagents, behave quite differently in the presence of Lewis acid catalysts, though the allylic geometry is generally stereodetermining in the absence of Lewis acids (entry 12).²⁶ We found that allylation of aldehydes with allylic trialkyltins took place at room temperature under neutral conditions by using a high-pressure technique (entry 13).²⁸ This result clearly indicates that a six-membered cyclic transition state is involved under ordinary neutral reaction conditions.

The diastereoselectivity of other crotylmethyls, such as boron,²⁹ aluminum, titanium, zirconium, and chromium compounds, is dictated by the allylic geometry, and these reactions must proceed through a six-mem-

(14) Yamamoto, Y.; Maeda, N.; Maruyama, K. *J. Chem. Soc., Chem. Commun.* 1983, 774.

(15) Yamamoto, Y.; Yatagai, H.; Ishihara, Y.; Maeda, N.; Maruyama, K. *Tetrahedron* 1984, 40, 2239.

(16) For acyclic transition states of enolate reactions, see: Murata, S.; Suzuki, M.; Noyori, R. *J. Am. Chem. Soc.* 1980, 102, 3248.

(17) Reetz, M. T.; Hullmann, M.; Massa, W.; Berger, S.; Rademacher, P.; Heymanns, P. *J. Am. Chem. Soc.* 1986, 108, 2405.

(18) Denmark, S. E.; Weber, E. J. *J. Am. Chem. Soc.* 1984, 106, 7970. See also: Seebach, D.; Golinski, J. *Helv. Chim. Acta* 1981, 64, 1413.

(19) Koreeda, M.; Tanaka, Y. *Chem. Lett.* 1982, 1297, 1299.

(20) Keck, G. E.; Abbott, D. E.; Boden, E. P.; Enholm, E. J. *Tetrahedron Lett.* 1984, 25, 3927.

(21) Hayashi, T.; Kabeta, K.; Hamachi, I.; Kumada, M. *Tetrahedron Lett.* 1983, 24, 2865. Hayashi, T.; Konishi, M.; Kumada, M. *J. Am. Chem. Soc.* 1982, 104, 4963. See also ref 12, footnote 12. For an anomaly in the diastereoselectivity of crotylsilane–aromatic acetal–Lewis acid condensations, see: Hosomi, A.; Ando, M.; Sakurai, H. *Chem. Lett.* 1986, 365.

(22) Sato, F.; Iida, K.; Ijima, S.; Moriya, H.; Sato, M. *J. Chem. Soc., Chem. Commun.* 1981, 1140.

(23) Reetz, M. T.; Sauerwald, M. *J. Org. Chem.* 1984, 49, 2292.

(24) Yamamoto, Y.; Maruyama, K. *J. Organomet. Chem.* 1985, 284, C45.

(25) Yamamoto, Y.; Saito, Y.; Maruyama, K. *J. Organomet. Chem.* 1985, 292, 311; *Tetrahedron Lett.* 1982, 23, 4959; *J. Chem. Soc., Chem. Commun.* 1982, 1326.

(26) Gambaro, A.; Marton, D.; Peruzzo, V.; Tagliavini, G. *J. Organomet. Chem.* 1981, 210, 57. Gambaro, A.; Boaretto, A.; Marton, D.; Tagliavini, G. *J. Organomet. Chem.* 1983, 254, 293.

(27) Pratt, A.; Thomas, E. J. *J. Chem. Soc., Chem. Commun.* 1982, 1115.

(28) Yamamoto, Y.; Maruyama, K.; Matsumoto, K. *J. Chem. Soc., Chem. Commun.* 1983, 489.

(29) Brown, H. C.; Bhat, K. S. *J. Am. Chem. Soc.* 1986, 108, 5919.

Yamamoto, Y.; Yatagai, H.; Maruyama, K. *J. Am. Chem. Soc.* 1981, 103, 1969.

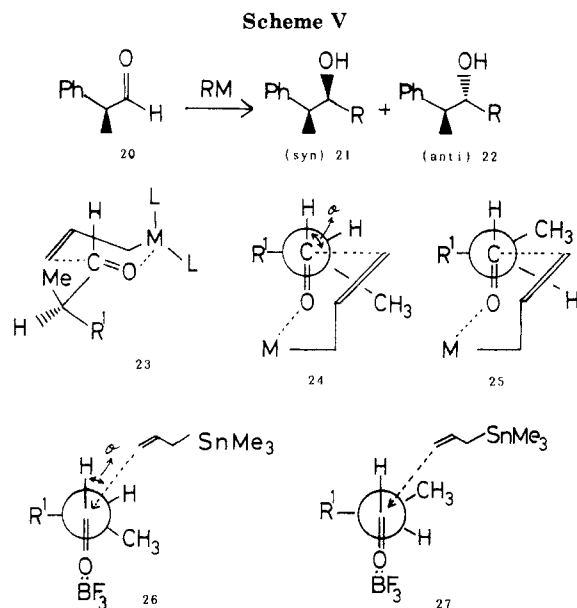

bered transition state.² Allylic boron derivatives, substituted with functional groups either at the γ -position³⁰ or at the α -position,^{5,31} also exhibit the normal diastereoselectivity. Similarly, the diastereoselectivity of other allylic metals with functional groups is normally controlled by the allylic geometry.³² Alkoxy substituted allylaluminates (18f), easily prepared in situ from the corresponding allylic carbanion (19), produced very high syn selectivity.^{25,33}

(ii) Generally, the reaction of allylmetallic compounds with ordinary chiral aldehydes having no ability to be chelated produces low Cram (syn) selectivity (Table II, entries 1–3).^{33a} Since the α -chiral center goes to the equatorial position of the chair transition state as shown in 23, the steric influence of ligand (L) does not reach the chiral center and the selectivity is determined only by steric factors at the chiral center. Inspection of a Dreiding model indicates that the angle (θ) in 24 which produces 21 is nearly 90° or even greater than 90°. Accordingly, the energy difference between 24 and 25 is relatively small, resulting in the low selectivity with allyl-9-BBN. With allyltin/Lewis acids in which an acyclic transition state is involved, θ is smaller than 90°⁴¹ and hence 26 is more stable than 27, resulting in the enhanced syn selectivity.⁴⁰

The syn selectivity of allylation and alkylation was remarkably enhanced by using RLi-crown or RMgX-crown reagents (entries 4–6).^{34a} Interestingly, the anti

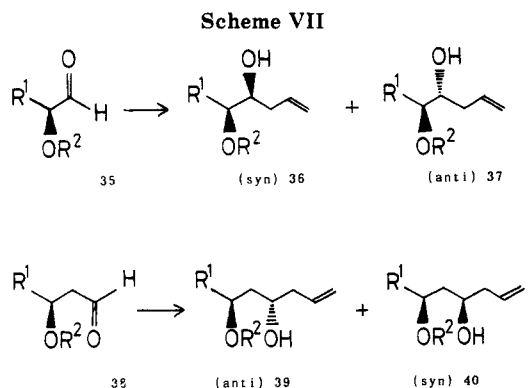
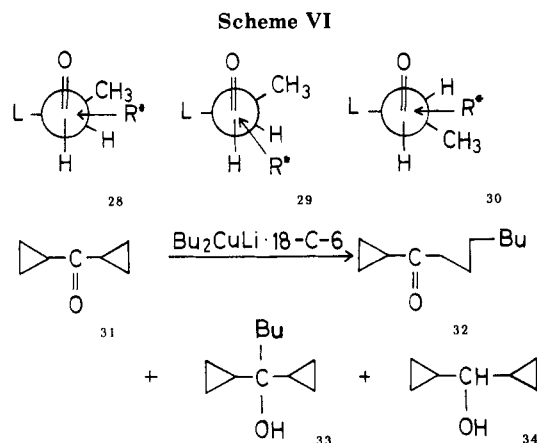

isomer (22) was produced preferentially with cuprate-crown reagents (entry 7).^{34a} Until now, only two methods are known for the anti selective alkylation of 20.³⁴

The enhanced syn selectivity with RLi-crown and Grignard-crown reagents may be explained as follows. The complexation of M⁺ by crown type compounds must diminish the electrophilic assistance of M⁺ toward carbonyl oxygen, leading to an increased syn selectivity irrespective of perpendicular (28) or nonperpendicular (29) attack.³⁵ Further, the crown ether presumably assists in increasing the state of aggregation.³⁶ Consequently, both loss of the electrophilic assistance and increase of the state of aggregation must enhance the syn selectivity.

The anti-Cram selectivity with R₂CuLi-crown reagents suggests the intervention of a radical mechanism.³⁷ In fact, the reaction of 31 with Bu₂CuLi·18-C-6 produced the ring-opening product 32 along with 33 and 34, though the reaction with Bu₂CuLi gave 33 exclusively. Accordingly, R₂CuLi-crown possesses greater ability to transfer electrons than R₂CuLi itself. If an electron-transfer mechanism is involved (R* = R[•]), 28–30 put more negative charge on oxygen than the normal transition state for a nucleophilic addition (R* = R⁻). It is therefore felt that the oxygen is, in effect, made larger, destabilizing 28 and 29 by increasing the CH₃-O⁻ interaction. Further, the directionality of R* attack may become perpendicular (30) in the radical

(30) (a) Hoffmann, R. W.; Kemper, B. *Tetrahedron Lett.* 1982, 23, 845. (b) Hoffmann, R. W.; Kemper, B. *Tetrahedron Lett.* 1981, 22, 5263. (c) Hoffmann, R. W.; Kemper, B. *Tetrahedron Lett.* 1980, 21, 4883. (d) Wuts, P. G. M.; Bigelow, S. S. *J. Org. Chem.* 1982, 47, 2498. Wuts, P. G. M.; Thompson, P. A.; Callen, G. R. *J. Org. Chem.* 1983, 48, 5398. (e) Tsai, D. J. S.; Matteson, D. S. *Tetrahedron Lett.* 1981, 22, 2751. (f) Yamamoto, Y.; Yatagai, H.; Saito, Y.; Maruyama, K. *J. Org. Chem.* 1984, 49, 1096.

(31) Moret, E.; Schlosser, M. *Tetrahedron Lett.* 1984, 25, 4491. Tsai, D. J. S.; Matteson, D. S. *Organometallics* 1983, 2, 236.

(32) Al: (a) Koreeda, M.; Tanaka, Y. *J. Chem. Soc., Chem. Commun.* 1982, 845. (b) Hoppe, D.; Lichtenberg, F. *Angew. Chem., Int. Ed. Engl.* 1982, 21, 372. Ti: (c) Sato, F.; Uchijima, H.; Iida, K.; Kobayashi, Y.; Sato, M. *J. Chem. Soc., Chem. Commun.* 1983, 921. (d) Hoppe, D.; Kramer, T. *Angew. Chem., Int. Ed. Engl.* 1986, 25, 160. Certain functionalized trans-crotylchromium(II) in the presence of AlHCl₂ exhibited syn selectivity: Okuda, Y.; Nakatsukasa, S.; Oshima, K.; Nozaki, H. *Chem. Lett.* 1985, 481.

(33) (a) Yamamoto, Y.; Komatsu, T.; Maruyama, K. *J. Organomet. Chem.* 1985, 285, 31. (b) Yamaguchi, M.; Mukaiyama, T. *Chem. Lett.* 1982, 237.

(34) (a) Yamamoto, Y.; Maruyama, K. *J. Am. Chem. Soc.* 1985, 107, 6411. (b) Maruoka, K.; Itoh, T.; Yamamoto, H. *J. Am. Chem. Soc.* 1985, 107, 4573.

(35) Calculations predict the importance of the electrophilic assistance for the stereoselectivity: Anh, N. T. *Top. Curr. Chem.* 1980, 88, 145.

(36) Richey, H. G., Jr.; King, B. A. *J. Am. Chem. Soc.* 1982, 104, 4672.

(37) A-Ibarra, C.; Arjona, O.; P-Ossorio, R.; P-Rubalcaba, A.; Quiroga, M. L.; Santemesas, M. J. *J. Chem. Soc., Perkin Trans. 2* 1983, 1645.

Scheme VIII

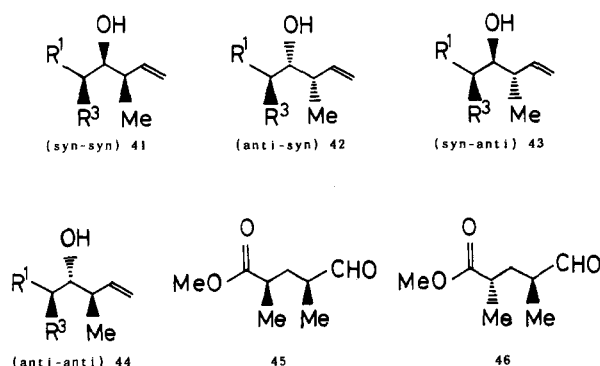

Scheme IX

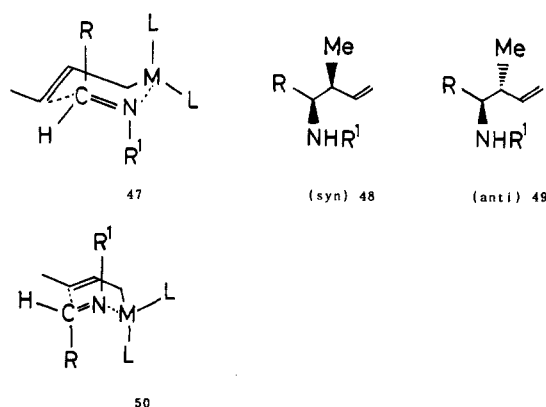

addition.³⁸ Taken together, **30** becomes more stable than **28** and **29**.

It was thought that $R^-NBu_4^+$ should exhibit enhanced syn selectivity and $R_2Cu^-NBu_4^+$ should produce the anti isomer preferentially. In fact, such "naked" anions and "naked" cuprates exhibited a similar stereochemical behavior as the RM crown and cuprate crown reagents, respectively (entries 8 and 9).³⁹

Excellent selectivity has been realized in α - and γ -alkoxy substituted aldehydes (**35** and **38**), in which chelation through the metal plays an important role for stereocontrol.^{1f,42a,b} We are now in a position to obtain chelation products (**36** and **39**) exclusively through the chelation concept. Moreover, the nonchelation adduct (**37**) can be produced with high stereoselectivity.^{1f,42} The concept of double asymmetric synthesis⁴³ becomes very important to obtain selectively both diastereoisomers. Unfortunately, the stereoselective synthesis of **40** has not yet been realized.

(iii) If complete 3C control is achieved and all four diastereomers (**41–44**) can be obtained selectively, it becomes theoretically possible to control the stereochemistry of more consecutive chiral carbon chains, such as 4C and 5C. With **35**, diastereomers **41–44** ($R^3 = OR^2$) can be prepared selectively; **41** was obtained via crotyltins/ BF_3 ,^{44a} **43** was produced through crotylchromium,^{44b} and **42–44** were obtained with crotylboronates.^{44c} The selectivity of the higher ordered asymmetric induction (iii) can generally be predicted on the basis of the selectivities observed in (i) and (ii).^{33a} With **20**, **41–43** ($R^1 = Ph$, $R^3 = Me$) can be produced

with high stereoselectivity; **41** was obtained via crotyltins/ BF_3 ,^{33a} and **42** and **43** were prepared from crotylboronates^{43c} and -titanium reagents.^{32d}

The reaction of **45** with crotyltins in the presence of 1 equiv of BF_3 produced **42** ($R^3 = Me$, $R^1 = CH_2C(Me)CO_2Me$),⁴⁵ while the reaction of **46** gave **41** ($R^3 = Me$, $R^1 = CH_2C(Me)CO_2Me$).⁴⁶ The reason for this difference is not clear, but the result provides an interesting example of remote chirality control.

Reactions of Aldimines

(i) The trans geometry of aldimines necessarily forces electrophiles (Lewis acids or metals) to coordinate the nitrogen atom syn to the R group. Therefore, the R group must go to the axial position in the chair transition state (**47**). Judging from both transition states (**10** and **47**), the opposite diastereoselectivity was expected in the reaction of imines. In fact, most of reactions with (*E*)-crotyl-9-BBN produced the syn homochiral amine (**48**) predominantly.⁴⁷ With increase of the steric bulk of the R group or with aryl substituent in the R^1 group, the anti isomer (**49**) was obtained preferentially. The 1,3 diaxial interaction between the R group and the bridgehead proton of the 9-BBN ring and the 1,2 axial-equatorial interaction between the R group and the Me group in **47** increase with the steric bulk of the R group. Under such circumstances, the boat transition state (**50**) may be more stable than **47**, leading to predominant formation of **49**. Consequently, the diastereoselectivity of imines is not straightforward but depends upon the nature of substituents R and R^1 .⁴⁸ The reason may be due to relatively small energy differences between various transition states (**47**, **50**, ...) in comparison with those of aldehydes.

The reaction of benzylideneaniline with crotyltin in the presence of BF_3 again gave **48** ($R = R^1 = Ph$) predominantly.⁴⁷ Use of $TiCl_4$ as a Lewis acid made the condensation facile, producing **48** with very high stereoselectivity.⁴⁹ With crotyllithium and -magnesium reagents, again **48** was produced predominantly.⁴⁷

(ii) Since the α -chiral center of **51** goes to the axial position in **47**, the selectivity must depend upon both the original steric factor of the chiral center and the steric influence of L (cf. **23**). Thus, enhancement of the

(38) Padden-Row, M. N.; Rondon, N. G.; Houk, K. N. *J. Am. Chem. Soc.* **1982**, *104*, 7162.

(39) Yamamoto, Y.; Matsuoka, K. *J. Chem. Soc., Chem. Commun.*, in press.

(40) Yamamoto, Y.; Nishii, S.; Maruyama, K. *J. Chem. Soc., Chem. Commun.* **1986**, 102.

(41) Heathcock, C. H.; Flippin, L. A. *J. Am. Chem. Soc.* **1983**, *105*, 1667. Remarkable enhancement was not observed for ordinary aldehydes even with the aid of the organotin/ $TiCl_4$.

(42) (a) Keck, G. E.; Boden, E. P. *Tetrahedron Lett.* **1984**, *25*, 265. (b) Shimagaki, M.; Takubo, H.; Oishi, T. *Tetrahedron Lett.* **1985**, *26*, 6235. (c) Roush, W. R.; Walts, A. E.; Hoong, L. K. *J. Am. Chem. Soc.* **1985**, *107*, 8186. (d) Brown, H. C.; Bhat, K. S.; Randad, R. S. *J. Org. Chem.* **1987**, *52*, 319.

(43) (a) Masamune, S.; Choy, W.; Peterson, J. S.; Sita, L. R. *Angew. Chem., Int. Ed. Engl.* **1985**, *24*, 1. (b) Heathcock, C. H.; Pirrung, M. C.; Lampe, J.; Buse, C. T.; Young, S. D. *J. Org. Chem.* **1981**, *46*, 2290. (c) Hoffmann, R. W.; Zeiss, H. J. *Angew. Chem., Int. Ed. Engl.* **1980**, *19*, 218.

(44) (a) Keck, G. E.; Boden, E. P. *Tetrahedron Lett.* **1984**, *25*, 1879. (b) Fronza, G.; Fuganti, C.; Grasselli, P.; Fantoni, G. P. *Chem. Lett.* **1984**, 335. (c) Roush, W. R.; Adam, M. A.; Walts, A. E.; Harris, D. J. *J. Am. Chem. Soc.* **1986**, *108*, 3422. Roush, W. R.; Halterman, R. L. *J. Am. Chem. Soc.* **1986**, *108*, 294. (d) For oxygen-substituted boronates, see: Wuts, P. G.; Bigelow, S. S. *J. Org. Chem.* **1983**, *48*, 3489. Roush, W. R.; Michaelides, M. R. *Tetrahedron Lett.* **1986**, *29*, 3353.

(45) Maruyama, K.; Ishihara, Y.; Yamamoto, Y. *Tetrahedron Lett.* **1981**, 4235.

(46) Yamamoto, Y.; Taniguchi, K.; Maruyama, K. *J. Org. Chem.* **1985**, *50*, 3115.

(47) Yamamoto, Y.; Komatsu, T.; Maruyama, K. *J. Org. Chem.* **1985**, *50*, 3115.

(48) Hoffmann, R. W.; Endesfelder, A., submitted for publication.

(49) Keck, G. E.; Enholm, E. J. *J. Org. Chem.* **1985**, *50*, 146.

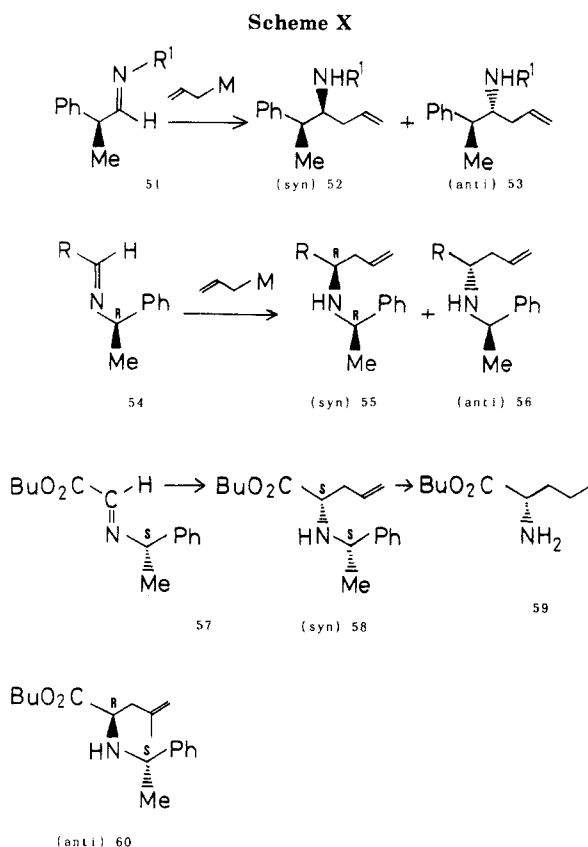

syn selectivity was expected owing to the stereoelectronic effect of the imine group. In fact, syn selectivity approaching 100% was realized in the reaction of **51** ($R^1 = i\text{-Pr}$) with allyl-9-BBN.⁵⁰ The allyltin-TiCl₄ reaction also produced excellent selectivity; **52:53** = 92:8.⁵¹

The interaction between the R group and L in **47** is a sort of 1,3 diaxial interaction. A sort of 1,2 axial-equatorial interaction between the R¹ group and L may create high asymmetric induction. The reaction of **54** ($R = i\text{-Pr}$) with allyl-9-BBN gave the adducts in a ratio of **55:56** = 92:8.⁵⁰ The reaction of allyltin-TiCl₄ also produced good selectivity (82:18). The 1,2 asymmetric induction can be explained by the modified Cram or Felkin model, and the 1,3 asymmetric induction can be accounted for by the extended Cram model.⁵¹

The high 1,3 asymmetric induction was applied to the chiral synthesis of amino acid derivatives.⁵² The reaction of α -imino ester (**57**) with allyl-9-BBN gave **58** in 92% yield with 92% ee, which was easily converted to L-norvaline butyl ester (**59**) upon reduction with H₂/cat. Pd(OH)₂. To our surprise, the reaction of **57** with methallyl-9-BBN produced **60** in 80% yield with 90% ee.⁵¹ Therefore, the direction of chiral induction is entirely opposite between allylboration and methallylboration.

The chair transition state of the methallylboration is presumably highly destabilized owing to three 1,3 diaxial interactions, and thus the reaction must proceed through a boat transition state like **50**.⁵¹ The direction of chiral induction in aldehydes is identical irrespective of the allyl-, methallyl-, and prenylboration.⁵³ An

(50) Yamamoto, Y.; Komatsu, T.; Maruyama, K. *J. Am. Chem. Soc.* **1984**, *106*, 5031.

(51) Yamamoto, Y.; Nishii, S.; Maruyama, K.; Komatsu, T.; Ito, W. *J. Am. Chem. Soc.* **1986**, *108*, 7778.

(52) Yamamoto, Y.; Ito, W.; Maruyama, K. *J. Chem. Soc., Chem. Commun.* **1985**, 1131.

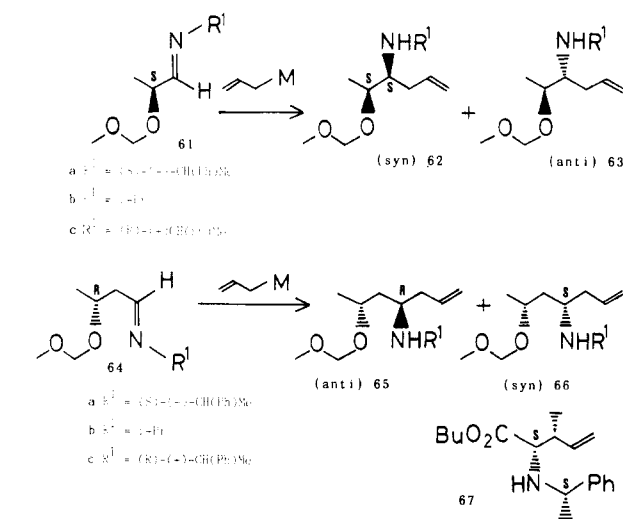

anomaly in the methallylboration may be due to small energy differences between various transition states in the imine reactions, as mentioned above.

High 1,2 asymmetric allylation of **61** was realized by choosing the metal.⁵⁴ The chelation product (syn) (**62**) was produced predominantly via allyl-MgCl, -AlEt₃MgCl, and -ZnBr, regardless of the R¹ group. The highest selectivity was achieved in the reaction of **61c** with allyl-AlEt₃MgCl (**62:63** = 95:5). The anti isomer (**63**) was obtained with allyl-Ti(Oi-Pr)₃, -B(OMe)₂, and -9-BBN irrespective of the R¹ substituent. Accordingly, the direction of chiral induction is dictated primarily by the chelating ability of metals, and the second chiral center of R¹ does not exert a strong influence on the chiral induction.

On the other hand, the chirality of R¹ plays an important role in the 1,3 asymmetric allylation of **64**.⁵⁴ The chelation product (anti) (**65**) was again produced predominantly in the reaction of **64a** and **64b** with allyl-MgCl, -AlEt₃MgCl, and -ZnBr, while **64c** gave **66** upon treatment with allyl-MgCl. The nonchelation product (**66**) was given in the reaction of **64c** with allyl-9-BBN, while the same reaction of **64a** produced **65**. In conclusion, **64a** prefers **65** and **64c** favors **66** regardless of allylmetals.

(iii) We examined the reactions of **51** and **54** with crotylmetals, but excellent diastereoselectivity has not been achieved yet. High enantio- and diastereoselectivity was realized in the reaction of **57** with crotyl-9-BBN.⁵¹ The syn-syn isomer (**67**) was produced in the ratio of 93:3:3:1, which was converted to allo-erythro-isoleucine butyl ester. Consequently, the selectivity of **67** is in good agreement with the selectivity shown in (i) and (ii).

Reactions of α,β -Unsaturated Carbonyl Compounds

(i) The reaction of Michael acceptors (**68**) with crotyl-MgCl, -9-BBN, -Ti(Oi-Pr)₃, and -ZrCp₂Cl gave the anti adduct (**69**) predominantly.⁵⁵ The anti selectivity

(53) Brown, H. C.; Jadhav, J. K. *J. Am. Chem. Soc.* **1983**, *105*, 2029. Brown, H. C.; Jadhav, J. K. *Tetrahedron Lett.* **1984**, *25*, 1215. Brown, H. C.; Jadhav, P. K.; Perumal, P. T. *Tetrahedron Lett.* **1984**, *25*, 5111.

(54) Yamamoto, Y.; Komatsu, T.; Maruyama, K. *J. Chem. Soc., Chem. Commun.* **1985**, 814.

(55) Yamamoto, Y.; Nishii, S.; Maruyama, K. *J. Chem. Soc., Chem. Commun.* **1985**, 386.

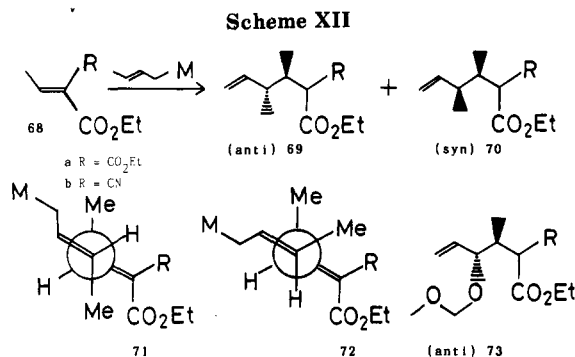

can be explained by an acyclic transition state; 71, which produces 69, is more stable for steric reasons than 72, which gives 70. Generally speaking, the diastereoselectivity via enolates⁵⁶ is more sensitive to variations of the double-bond geometry, reaction conditions, and substrates than the selectivity via allylmetals. The Lewis acid mediated addition of crotyl tin to 68 again produced 69 predominantly.⁵⁷ Quite similarly, the addition of 18c gave 73 with high stereoselectivity.

(ii) The reaction of 74 with allyl-Ti(Oi-Pr)₃, -SiMe₃/TiCl₄, and -SnBu₃/TiCl₄ gave 75a with high stereoselectivity; 75a:76a = >92:8.⁵⁷ The addition to 74b and 74c did not occur, but the ketone (74d) reacted with allyl-SiMe₃/TiCl₄ to give 75d predominantly (4:1).⁵⁸ The anti selectivity can be accounted for by a modified Felkin (77) or Cram model.

The conjugate addition to 78a produced 80 with high selectivity (>9:1) regardless of the reagent type. The allylation of 78b and 78c again did not take place, but the alkylation was realized with RCu:BF₃.⁵⁹ Quite interestingly, the alkylation of 78b gave the anti isomer, while that of 78c produced the syn adduct. The allylation of the conjugate ketones took place with allyl-silane/TiCl₄.⁵⁸ Here again, 78d produced 79d and 78e gave 80e. The anti selectivity of 78b and 78d may be explained by 81. The interaction between the electron-deficient p orbital and the lone pair of oxygen

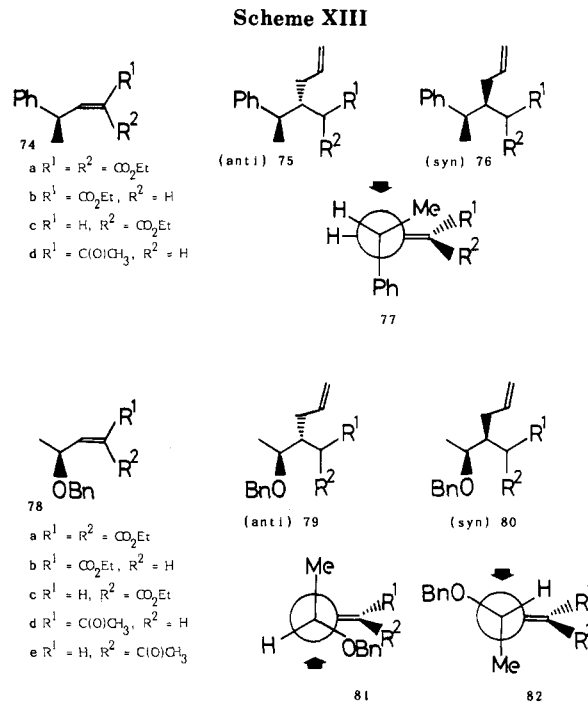

would favor 81 rather than Felkin or Cram type conformation. The cis geometry of 78c and 78e forces one to take 82 to diminish the steric repulsion between R² and the allylic substituent, giving the syn isomer.

Concluding Remarks

Aldol and enolate methodologies have a long history and occupy an important position for controlling acyclic stereochemistry. Despite its short history, the allylic organometallic way is becoming an equally important methodology. The two methods are often complementary from the synthetic point of view. Now, 2C control reaches completion, and we are approaching accomplishment of 3C control. Three major concepts to accomplish high acyclic stereocontrol via allylmetals come to our hand: metal chelation, double asymmetric induction, and Lewis acid effect. Stereocontrol of more consecutive carbon centers will be achieved by a combination of these concepts.

I am deeply indebted to my co-workers, whose names appear in our papers cited in this Account. Our research has been supported by the Ministry of Education, the Mitsubishi Foundation, and the Sound Technology Foundation.

(56) (a) Yamaguchi, M.; Tsukamoto, M.; Tanaka, S.; Hirao, I. *Tetrahedron Lett.* 1984, 25, 5661. (b) Heathcock, C. H.; Norman, M. H.; Uehling, D. E. *J. Am. Chem. Soc.* 1985, 107, 2797. (c) Heathcock, C. H.; Oare, D. A. *J. Org. Chem.* 1985, 50, 3022.

(57) Yamamoto, Y.; Nishii, S., unpublished data.

(58) Heathcock, C. H.; Kiyooka, S.; Bulmenkopf, T. A. *J. Org. Chem.* 1986, 51, 3252; 1984, 49, 4214.

(59) Yamamoto, Y.; Nishii, S.; Ibuka, T. *J. Chem. Soc., Chem. Commun.* 1987, 464.